



WHITE-RODGERS

1F83-71

Non-Programmable Electronic
Digital Automatic Changeover Multi-stage Thermostat
**INSTALLATION AND
OPERATION INSTRUCTIONS**

Operator: Save these instructions for future use!

**FAILURE TO READ AND FOLLOW ALL INSTRUCTIONS CAREFULLY
BEFORE INSTALLING OR OPERATING THIS CONTROL COULD CAUSE
PERSONAL INJURY AND/OR PROPERTY DAMAGE.**

DESCRIPTION

Your new White-Rodgers Digital Multi-stage Thermostat uses the technology of a solid-state microcomputer to provide precise time/temperature control.

Features:

- Simultaneous heat and cool setpoint storage
 - Optional **C** terminal (dual power option)
 - Optional **B** and **O** terminals
 - Preprogrammed temperature control
- LCD continuously displays setpoint and room temperature
 - °F/°C convertibility
 - Temperature range 45° to 90°F
 - Two-stage heat/two-stage cool
 - Armchair programming capability

PRECAUTIONS

This thermostat is intended for use with a 24-volt system; do not use this thermostat with a millivolt or line voltage system. If in doubt about whether your wiring is millivolt, line, or low voltage, have it inspected by a qualified heating and air conditioning contractor or electrician.

Do not exceed the specification ratings.

All wiring must conform to local and national electrical codes and ordinances.

This control is a precision instrument, and should be handled carefully. Rough handling or distorting components could cause the control to malfunction.

⚠ CAUTION

To prevent electrical shock and/or equipment damage disconnect electric power to system at main fuse or circuit breaker box until installation is complete.

⚠ WARNING

Do not use on circuits exceeding specified voltage. Higher voltage will damage control and could cause shock or fire hazard.

Do not short out terminals on gas valve or primary control to test. Short or incorrect wiring will damage thermostat and could cause personal injury and/or property damage.

SPECIFICATIONS

ELECTRICAL DATA

Electrical Rating:

- 20 to 30 VAC 50/60 Hz. or D.C.
- 0.05 to 1.5 Amps (Load per terminal)
- 1.5 Amps Maximum Total Load** (All terminals combined)

THERMAL DATA

Setpoint Temperature Range:

45°F to 90°F (7°C to 32°C)

Operating Ambient Temperature Range:

32°F to 105°F

Operating Humidity Range:

0 to 90% RH (non-condensing)

Shipping Temperature Range:

-40°F to 150°F

APPLICATIONS

For use with:

- Heat/cool systems with up to two stages heat, two stages cool

DO NOT USE WITH:

- Millivolt systems
- Systems exceeding 30 VAC and 2.5 amps
- 3-wire zoned hydronic heating systems

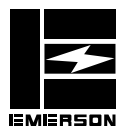

WHITE-RODGERS DIVISION
EMERSON ELECTRIC CO.
9797 REAVIS ROAD
ST. LOUIS, MISSOURI 63123-5398

Printed in U.S.A.

PART NO. 37-6126B

Replaces 37-6126A

0004

INSTALLATION

REMOVE OLD THERMOSTAT

1. Shut off electricity at the main fuse box until installation is complete. Ensure that electrical power is disconnected.
2. Remove the front cover of the old thermostat. **With wires still attached**, remove wall plate from the wall. If the old thermostat has a wall mounting plate, remove the thermostat and the wall mounting plate as an assembly.
3. **Identify each wire attached to the old thermostat using the labels enclosed with the new thermostat.**
4. Disconnect the wires from old thermostat one at a time. **DO NOT LET WIRES FALL BACK INTO THE WALL.**
5. Install new thermostat using the following procedures.

PRE-INSTALLATION SET-UP

1. Remove the packing material from the thermostat.
2. This thermostat is configured from the factory to operate a heat/cool, fossil fuel (gas, oil, etc.), forced air system with up to 2 stages of heat and 2 stages of cool. It is configured correctly for any system that **DOES NOT** require the thermostat to energize the fan on a call for heat.

If your system is an electric heat or heat-pump system that **REQUIRES** the thermostat to turn on the fan on a call for heat, locate the **GAS/ELECTRIC switch** on the back of the thermostat (see fig. 1) and switch it to the **ELECTRIC** position. This will allow the thermostat to energize the fan immediately on a call for heat. If you are unsure if the heating/cooling system requires the thermostat to control the fan, contact a qualified heating and air conditioning service person.

3. One jumper is located on the back of the thermostat, so that you may customize the thermostat to meet your individual preference (see fig. 1). In most applications, the factory jumper settings provide the most comfortable and convenient thermostat operation.

Jumper wire **W905** determines how fast the system cycles on and off, based on temperature change. As shipped from the factory, the thermostat will maintain a very consistent room temperature, usually within 1°F of the thermostat setting. To achieve a slower on and off cycle, providing a slightly wider temperature span, cut and separate jumper wire **W905**.

INSTALLING THE THERMOSTAT

1. Gently remove the cover by pulling it straight off the base. Forcing or prying on the unit may cause damage to the unit.
2. Remove the battery tab. With the batteries installed, the Armchair Programming feature allows you to program the thermostat before installing it on the wall.
3. Pull wires through the hole in the thermostat base and place the base over the hole in the wall. Mark mounting hole locations on the wall using the base as a template.
4. Move the base out of the way. Drill mounting holes.
5. Fasten the base loosely to the wall, as shown in fig. 2, using two mounting screws. Place a level against the bottom of the base, adjust until level, and then tighten the screws. (Leveling is for appearance only and will not affect thermostat operation.) If you are using existing mounting holes, or if the holes drilled are too large and do not allow you to tighten the base snugly, use plastic screw anchors to secure the base.

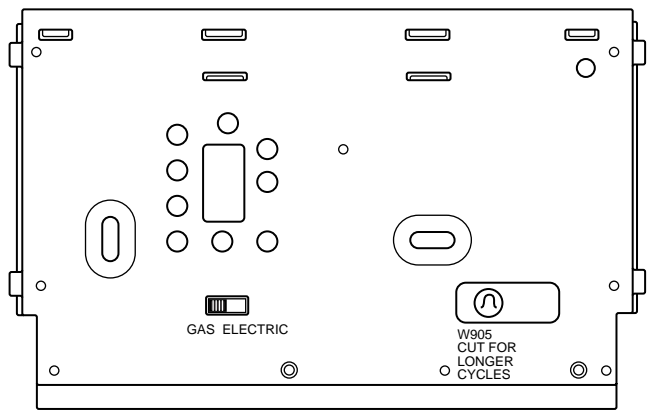

Figure 1. Back of thermostat base

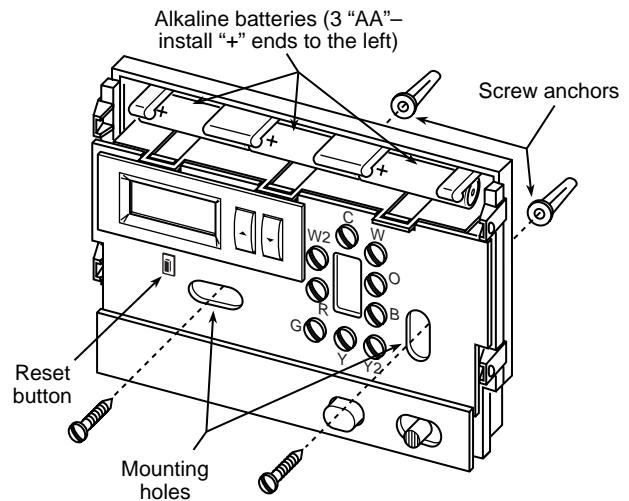

Figure 2. Thermostat base

6. Check that the system is turned off. Connect the wires beneath the terminal screws on the base using the appropriate wiring diagram (see figs. 3 through 5).
7. Push excess wire into wall and plug hole with a fire-resistant material (such as fiberglass insulation) to prevent drafts from affecting thermostat operation.

CHECK THERMOSTAT OPERATION

NOTE

If at any time during testing, your system does not operate properly, contact a qualified serviceperson.

Fan Operation

1. Turn on power to the system.
2. Press SYSTEM button until the system is **OFF**.
3. Move FAN switch to **ON**. The blower should begin to operate.
4. Move FAN switch to **AUTO** position. The blower should stop within a short period of time.

(Instructions continue on page 4.)

NOTE

The following wiring diagrams show **typical** terminal identification and wiring. For proper installation, refer to the original manufacturer's instructions.

NOTE

Relay contacts shown are thermostatically operated.

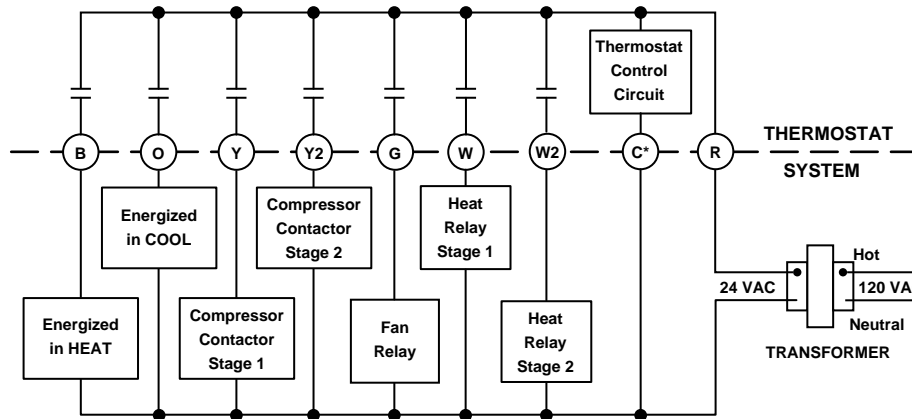

* The 24 Volt neutral connection to terminal **C** on the thermostat is not required if you replace the batteries once a year with fresh "AA" Energizer® alkaline batteries.

Figure 3. Typical wiring diagram for single transformer systems

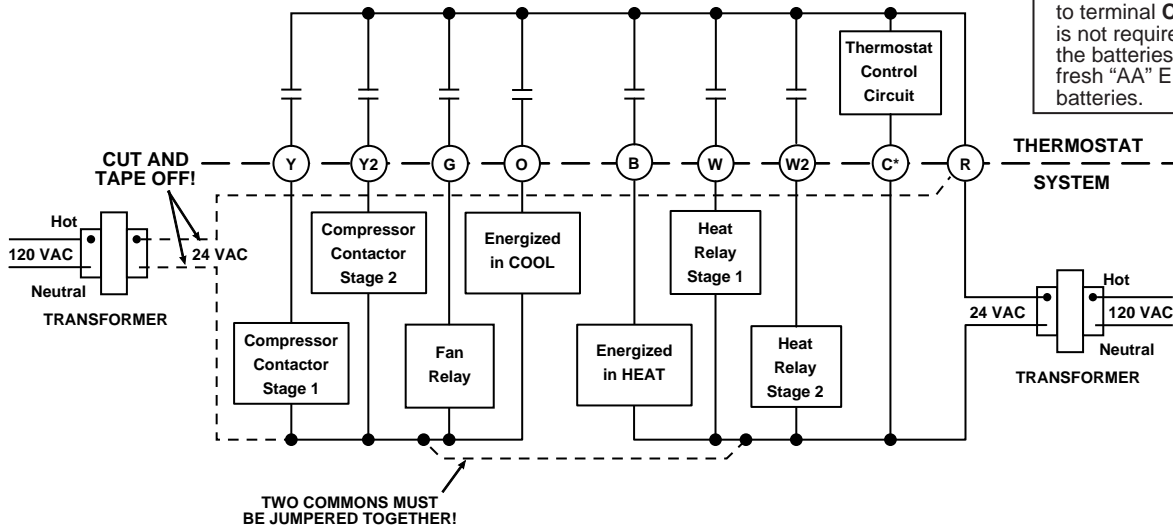

* The 24 Volt neutral connection to terminal **C** on the thermostat is not required if you replace the batteries once a year with fresh "AA" Energizer® alkaline batteries.

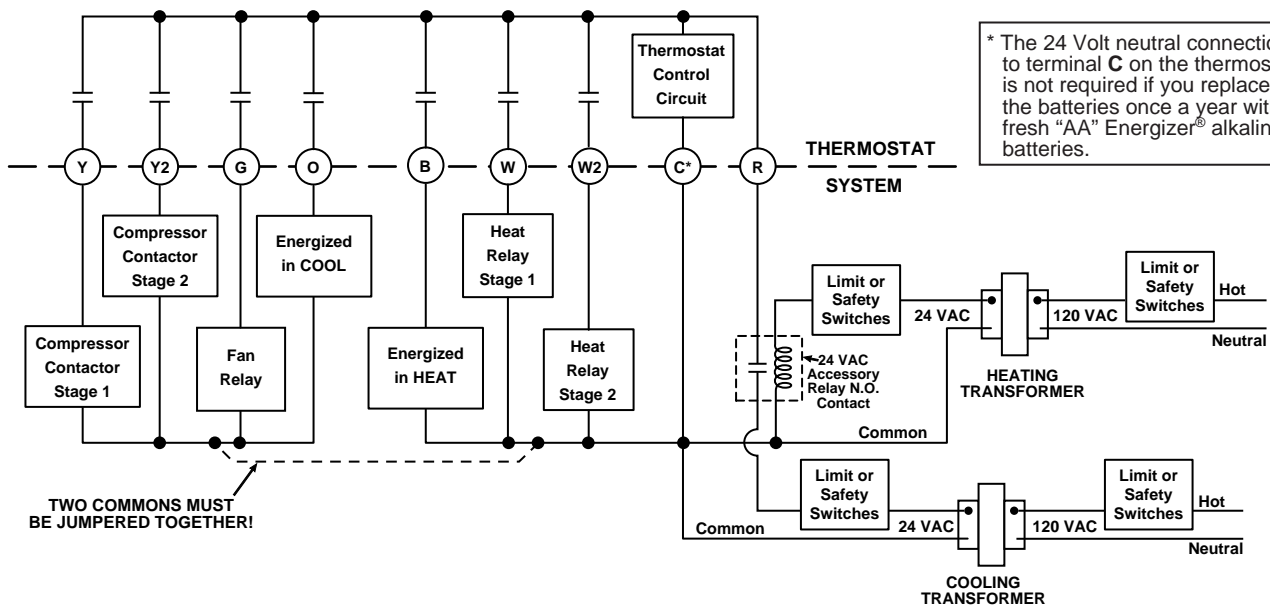

Figure 4. Typical wiring diagram for two-transformer systems with NO safety circuits



* The 24 Volt neutral connection to terminal **C** on the thermostat is not required if you replace the batteries once a year with fresh "AA" Energizer® alkaline batteries.

Figure 5. Typical wiring diagram for two-transformer systems with safety circuits in BOTH systems

Heating System

1. Press SYSTEM button to turn thermostat to **HEAT**.
2. Press  to adjust thermostat setting to 90° and **hold for five seconds**. After you release the button, both stages of the heating system should begin to operate within five seconds.
3. Press  to adjust temperature setting below room temperature. The auxiliary heating system will stop immediately and the first stage will stop within three to four minutes.

Cooling System

CAUTION

To prevent compressor and/or property damage, if the outdoor temperature is below 50°F, DO NOT operate the cooling system.

1. Press SYSTEM button to turn thermostat to **COOL**.
2. Press  to adjust thermostat setting to 45° and **hold for five seconds**. After you release the button, the blower should come on immediately on high speed, followed by cold air circulation. Both stages of the cooling system should begin to operate (if you have a two-stage cooling system).

If the fan is running but the compressor is not running and the word **COOL** is flashing, the compressor lockout feature is operating (see **Lockout Bypass Option** to temporarily override the compressor lockout feature during testing).

3. Press  to adjust temperature setting above room temperature. The cooling system should stop operating.



NOTE

During normal operation, the second stage of heat or cool may take 15 to 30 minutes to turn on. The delay varies depending on the performance of the first stage. Typically the second stage will come on sooner in more severe weather, while in milder weather it will take longer. There is no adjustment to this feature, as it is designed to maximize both comfort and efficiency.

LOCKOUT BYPASS OPTION

FOR QUALIFIED SERVICE TECHNICIANS' USE ONLY. OPERATORS SHOULD NOT USE THIS FEATURE DUE TO POSSIBILITY OF EQUIPMENT OR PROPERTY DAMAGE, OR PERSONAL INJURY.



COMPRESSOR SHORT TERM CYCLE PROTECTION

During normal operation, this thermostat has a built-in short term (5-minute) time delay. During this 5-minute period, the thermostat will lock out the compressor to allow head pressure to stabilize. If you want to override this feature while testing thermostat operation, simply press  and  buttons at the same time.

DO NOT USE THE LOCKOUT BYPASS OPTION UNLESS THE COMPRESSOR OIL HEATERS HAVE BEEN OPERATIONAL FOR 6 HOURS AND THE SYSTEM HAS NOT BEEN OPERATIONAL FOR AT LEAST 5 MINUTES.

Before you begin using your thermostat, you should be familiar with its features and with the display and the location and operation of the thermostat buttons. Your thermostat consists of two parts: the **thermostat cover** and the **base**. To remove the cover, gently pull it straight out from the base. To replace the cover, line up the cover with the base and press gently until the cover snaps onto the base.

THE THERMOSTAT BASE

Other than  and , the following buttons and switches are located behind the door on the bottom of the thermostat cover (see fig. 6). Pull the door down to open it.

The Thermostat Buttons and Switches



- ① (Red arrow) Raises temperature setting.
- ② (Blue arrow) Lowers temperature setting.
- ③ SYSTEM button (COOL, OFF, HEAT, AUTO).
- ④ FAN switch (ON, AUTO).



The Display

- ⑤ HT is displayed when the SYSTEM button has been pressed to put the thermostat in the HEAT mode. CL is displayed when the SYSTEM button has been pressed to put the thermostat in the COOL mode. CL is displayed (flashing) when the compressor is in lockout mode. AUTO is displayed when the SYSTEM button has been pressed to put the thermostat in the automatic changeover (AUTO) mode. 1+2 indicates the number of stages the thermostat is calling for.
- ⑥ Displays current temperature.
- ⑦ LOCK is displayed when keypad lockout has been activated.
- ⑧ Displays current setpoint temperature (this is blank when SYSTEM button has been pressed to turn the system OFF).
- ⑨ LO BATTERY is displayed when approximately 70% of battery life has been exhausted.

OPERATING FEATURES

Now that you are familiar with the thermostat buttons and display, read the following information to learn about the many features of the thermostat.

- **TEMPERATURE SETPOINT** — Press  or  until the display shows the temperature you want.
- **SIMULTANEOUS HEATING/COOLING SETPOINT STORAGE** — You can enter both your heating and cooling setpoints at the same time.
- **AUTOMATIC CHANGEOVER** — If you have a heating/cooling system, you can set the thermostat to automatically switch from heat to cool as needed to maintain setpoint temperature. To select this mode, press SYSTEM button until AUTO is displayed along with HEAT or COOL.

In AUTO mode, pressing  and  at the same time will change the displayed setpoint temperature to the setpoint of the other mode (HEAT or COOL). This allows you to change both the HEAT and COOL setpoints, if desired.

- **TOTAL KEYPAD LOCKOUT** — This security feature allows you to lock out the thermostat buttons to prevent

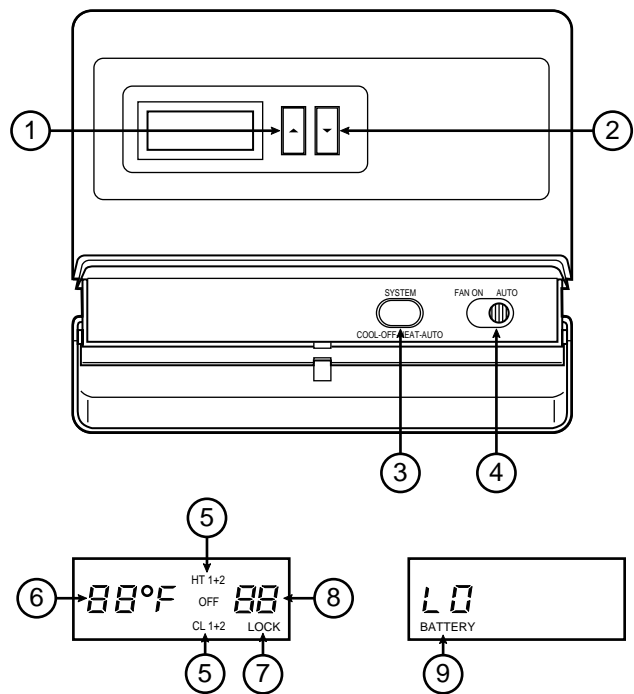









Figure 6. Thermostat display, buttons, and switches

unauthorized tampering. To select this feature, press  and SYSTEM button at the same time **and hold** until LOCK is displayed. To unlock the thermostat, press  and SYSTEM buttons at the same time until LOCK is no longer displayed.

- **°F/°C CONVERTIBILITY** — Press  and SYSTEM buttons until the temperature display is in Celsius. To display Fahrenheit, repeat the process.
- **TEMPERATURE DISPLAY ADJUSTMENT** — Your new thermostat has been accurately set in our factory. However, if you wish, you may adjust your new thermostat temperature display. This can be accomplished (within a $\pm 4^\circ\text{F}$ range) as follows:

1. Press and hold  and SYSTEM buttons at the same time until the actual temperature only is displayed (about 5 seconds).
2. Press  or  to adjust the displayed temperature to your desired setting. (To reset the temperature display back to the actual sensed temperature, press  and SYSTEM buttons at the same time again.)
3. Press SYSTEM to resume normal thermostat operation.

TROUBLESHOOTING

If your thermostat's display is frozen or displaying incorrectly, the thermostat may have been affected by static discharge or voltage variations. If this happens, press the RESET button (see fig. 2, page 2 for the location of the button). If pressing the RESET button does not correct the problem, contact a qualified service technician.

For optimum performance, we recommend replacing batteries once a year with fresh "AA" Energizer® alkaline batteries.

