



WHITE-RODGERS

1E56-444

Low Voltage Heating/Cooling Thermostat
INSTALLATION INSTRUCTIONS

Operator: Save these instructions for future use!

FAILURE TO READ AND FOLLOW ALL INSTRUCTIONS CAREFULLY BEFORE INSTALLING OR OPERATING THIS CONTROL COULD CAUSE PERSONAL INJURY AND/OR PROPERTY DAMAGE.

DESCRIPTION

This low voltage thermostat is designed to provide convenient control of the heating/cooling system. To provide greater room comfort, the sensitive spiral bimetal is combined with an adjustable heating anticipator and a fixed cooling anticipator to provide maximum comfort.

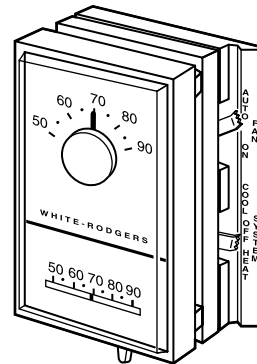

PRECAUTIONS

If in doubt about whether your wiring is millivolt, line, or low voltage, have it inspected by a qualified heating and air conditioning contractor, electrician, or someone familiar with basic electricity and wiring.

Do not exceed the specification ratings.

All wiring must conform to local and national electrical codes and ordinances.

This control is a precision instrument, and should be handled carefully. Rough handling or distorting components could cause the control to malfunction.

⚠ CAUTION

To prevent electrical shock and/or equipment damage, disconnect electric power to system at main fuse or circuit breaker box until installation is complete.

Do not short out terminals on gas valve or primary control to test. Short or incorrect wiring will burn out heat anticipator and could cause personal injury and/or property damage.

⚠ WARNING

Do not use on circuits exceeding 30 volts. Higher voltage will damage control and could cause shock or fire hazard.

CONTENTS

Description	1
Precautions	1
Specifications	2
Installation	2
Select Thermostat Location	
Route Wires to Location	
Attach Subbase to Wall	
Special System Configurations	
Electric Heat Furnaces (Single Transformer Systems Only)	
Two-Transformer Systems	
Heat Pump Applications	
Special Application Terminals	
Attach Thermostat to Subbase	
Operation & Maintenance	5
Adjusting Heat Anticipator	
Calibrating Thermostat	



WHITE-RODGERS DIVISION
EMERSON ELECTRIC CO.
9797 REAVIS ROAD
ST. LOUIS, MISSOURI 63123-5398

Printed in U.S.A.

PART NO. 37-4219B
Replaces 37-4219A
9623

SPECIFICATIONS

ELECTRICAL DATA

Switch Rating: 24 VAC (30 VAC max.)

Heating - 0.15 to 1.2 Amps

Cooling - 0 to 1.5 Amps

Switch Action: SPST - Sealed mercury switch

Anticipator Rating:

Heating - Adjustable from 0.15 to 1.2 Amps

Cooling - Fixed 24 VAC

THERMAL DATA

Temperature Range: 50°F to 90°F (10°C to 32°C)

Differential: 1°F

APPLICATIONS

The 1E56-444 is designed for use with

- Standard heating and cooling systems
- Electric heating and cooling systems
- Single stage heat pump systems
- Two-transformer systems
- Electronic air cleaners
- Humidifiers
- Zone dampers

This thermostat **CANNOT BE USED** with:

- Millivolt systems
- Multi-stage applications

INSTALLATION

SELECT THERMOSTAT LOCATION

Proper location insures that the thermostat will provide a comfortable home temperature. Observe the following general rules when selecting a location:

1. Locate thermostat about 5 ft. above the floor.
2. Install thermostat on a partitioning wall, not on an outside wall.
3. Never expose thermostat to direct light from lamps, sun, fireplaces or any temperature radiating equipment.
4. Avoid locations close to windows, adjoining outside walls, or doors that lead outside.
5. Avoid locations close to air registers or in the direct path of air from them.
6. Make sure there are no pipes or duct work in that part of the wall chosen for the thermostat location.
7. Never locate thermostat in a room that is warmer or cooler than the rest of the home, such as the kitchen.
8. Avoid locations with poor air circulation, such as behind doors or in alcoves.
9. The living or dining room is normally a good location, provided there is no cooking range or refrigerator on opposite side of wall.

ROUTE WIRES TO LOCATION

NOTE

All wiring must conform with local and national electrical codes and ordinances.

1. If an old thermostat being replaced is in a satisfactory location, and the wiring appears to be in good condition, use existing wiring. If in doubt, re-wire.
2. If a new location is chosen or if this is a new installation, thermostat wiring must first be run to the location selected.

3. Probe for obstructions in partition before drilling $\frac{1}{2}$ " hole in wall at selected location. Take up quarter round and drill a small guide hole for sighting (see fig. 1). From basement, drill $\frac{3}{4}$ " hole in partition floor next to guide hole. In houses without basements, drill $\frac{1}{2}$ " hole through ceiling and into partition from above (see fig. 1).
4. Through this hole drop a light chain, or 6" chain attached to a strong cord. Snag cord in basement with hooked wire. In houses without basements, drop cord through hole in ceiling and down partitioning; snag cord at the thermostat location.
5. Attach thermostat wires to cord and pull thermostat wires through hole in wall so that 6" of wire protrudes.

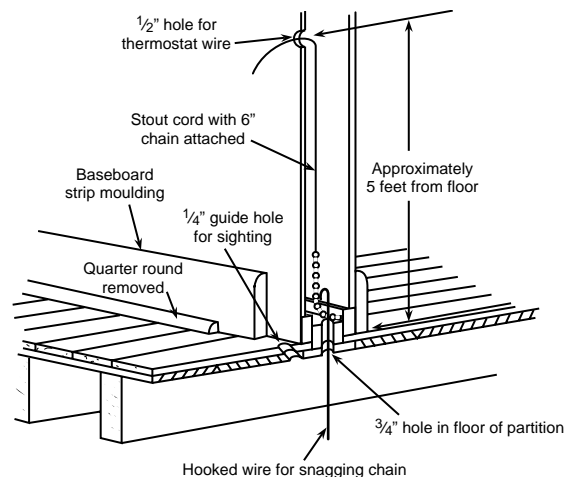

Figure 1. Routing thermostat wires

CAUTION

Take care when securing and routing wires so they do not short to adjacent terminals or rear of thermostat. Personal injury and/or property damage may occur.

NOTE

These typical wiring diagrams show only the terminal identification and wiring hookup. Always refer to wiring instructions, provided by equipment manufacturer, for system hookup operation.

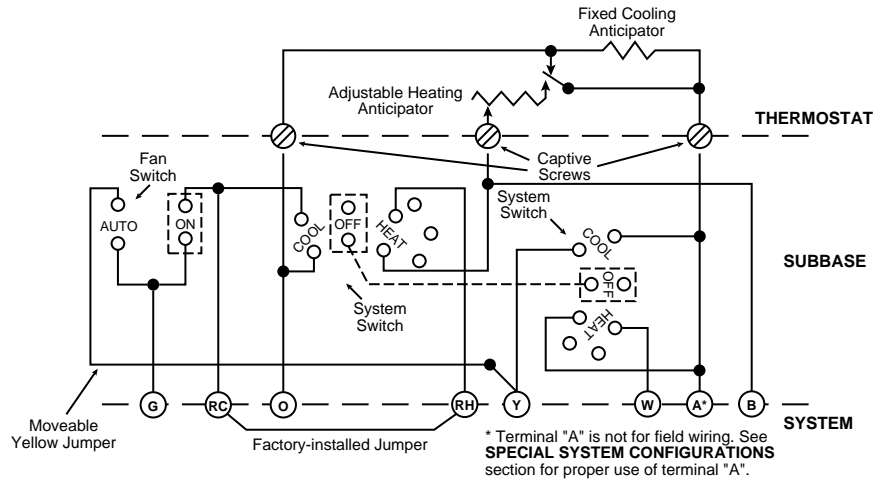

Figure 3. Typical wiring diagram (see figs. 4, 5, and 6 for typical system/thermostat wiring)

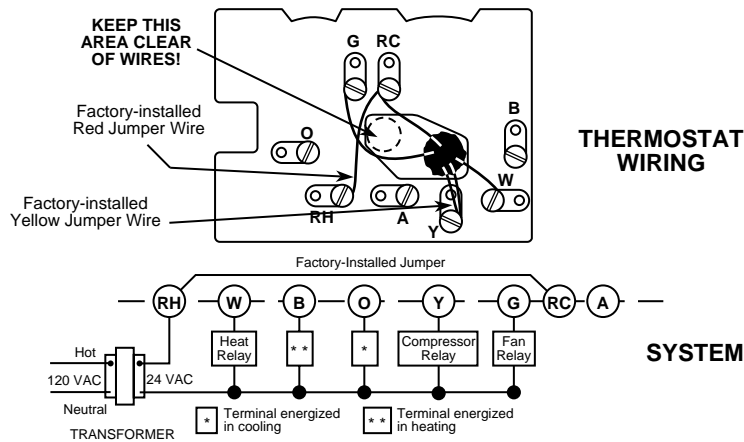

Figure 4. Typical wiring for single transformer heating/cooling system

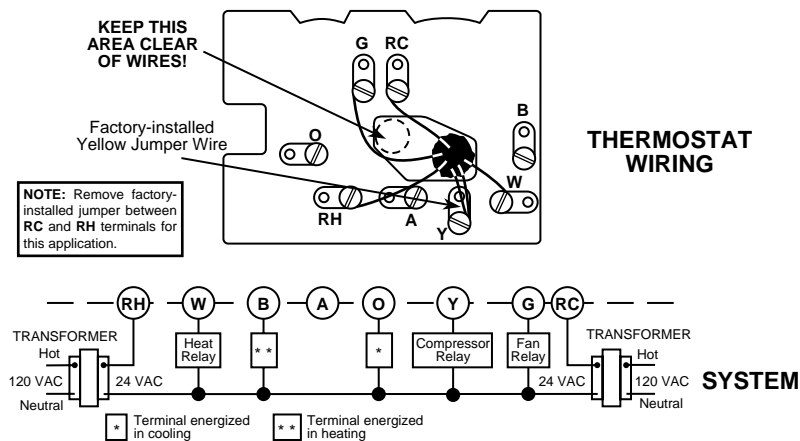

Figure 5. Typical wiring for two-transformer heating/cooling system

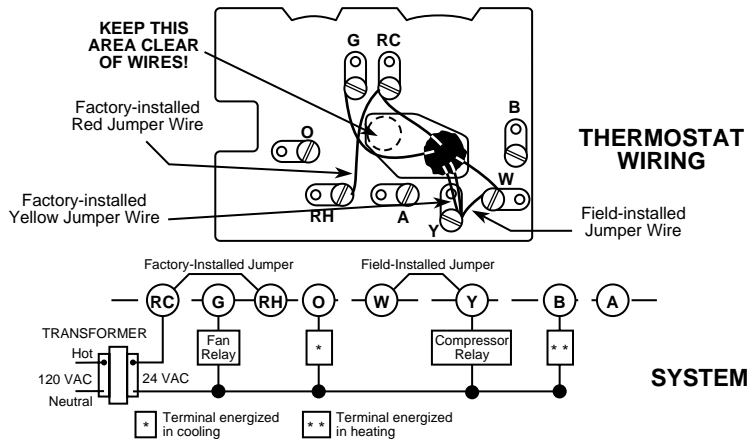

Figure 6. Typical wiring for single transformer, single stage heat pump system

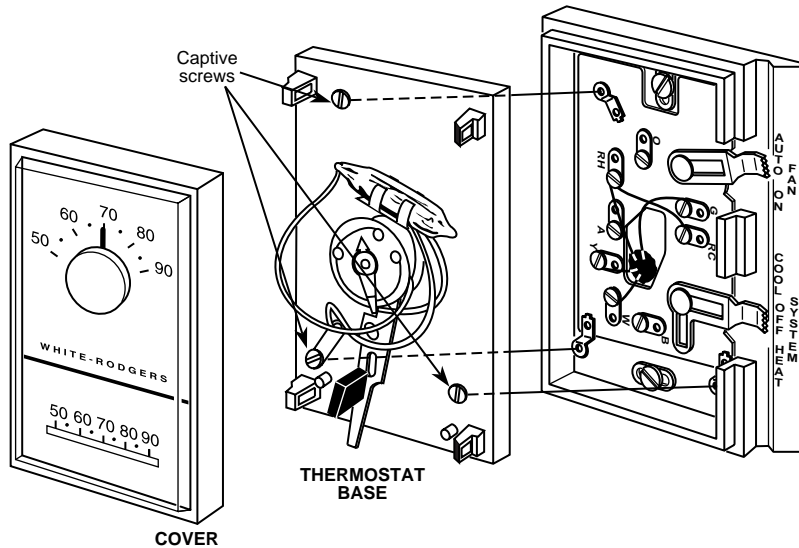

Figure 7. Attach thermostat to subbase

OPERATION & MAINTENANCE

This thermostat is easy to operate. Fig. 8 shows how the heating/cooling system and fan operate when the switches are in various positions. Use the system switch to select either heating or cooling, or to turn the heating/cooling system off. Use the fan switch to control fan operation. When the fan switch is in the **AUTO** position, the fan will cycle with the heating or cooling system (the fan will not run if the system switch is in the **OFF** position and the fan switch is in the **AUTO** position). When the fan switch is in the **ON** position, the fan will run continuously, regardless of system switch position (even if the system switch is set to **OFF**, the fan will run if the fan switch is in the **ON** position).

■ Shows switch position				OPERATION
FAN		SYSTEM		
AUTO	ON	COOL	HEAT	
■	□	□	□	No heating; no cooling; no fan
□	■	□	□	No heating; no cooling; fan runs continuously
□	■	■	□	Cooling system cycles from thermostat; fan runs continuously
■	□	■	□	Cooling system and fan cycle from thermostat
■	□	□	■	Heating system cycles from thermostat; fan cycles from fan control on furnace
□	■	□	■	Heating system cycles from thermostat; fan runs continuously

Figure 8. Subbase switching and thermostat/system operation

ADJUSTING HEAT ANTICIPATOR

⚠ CAUTION

The adjustable heat anticipator **WILL BURN OUT** if 25 VAC is applied directly to the thermostat by shorting out the primary control during testing. This may cause personal injury and/or property damage.

This thermostat is equipped with an adjustable heat anticipator and was preset at the factory to provide satisfactory operation of the heating system under normal conditions. If additional adjustments are necessary, they may be made as follows (see fig. 9):

1. Remove thermostat cover.
2. If heat cycle is too long, set heat anticipator to a slightly lower dial setting ($\frac{1}{2}$ division).
3. If heat cycle is too short, set heat anticipator to a slightly higher dial setting ($\frac{1}{2}$ division).
4. Replace thermostat cover.

CALIBRATING THERMOSTAT

This thermostat has been carefully adjusted at the factory and should not require recalibration.

Due to environmental conditions, during normal operation there may be a few degrees of difference between the indicator setting of the thermostat and actual room temperature. If the disagreement is appreciable, however, first make sure that the thermostat is properly located and leveled. Then, if recalibration still seems necessary, proceed as follows:

⚠ CAUTION

To prevent electrical shock and/or equipment damage, disconnect electrical power to the system until recalibration is complete.

1. The anticipator's heat may adversely affect thermostat recalibration. To prevent this, disconnect electrical power to the thermostat at the furnace, main fuse, or breaker box.
2. Move temperature adjustment lever to a setting about 5° above room temperature.
3. Remove thermostat cover. Slip $\frac{7}{32}$ " wrench onto hex nut beneath bimetal. While holding temperature adjustment lever stationary, turn hex nut clockwise until mercury shifts to the right end of the tube (see fig. 10).

4. Move temperature adjustment lever to lowest setting.
5. Replace thermostat cover. Wait 10 minutes for bi-metal temperature to stabilize. Do not stand near the thermostat during this period, as your breath and body heat will affect bimetal temperature.
6. Move temperature adjustment lever to correspond to actual room temperature. Then remove thermostat cover.
7. Slip $\frac{7}{32}$ " wrench onto hex nut. While holding temperature adjustment lever stationary, turn hex nut counter-clockwise until mercury just barely shifts to the left end of the tube (see fig. 10).
8. Replace thermostat cover and set temperature adjustment lever to desired temperature. Turn on electrical power to system.

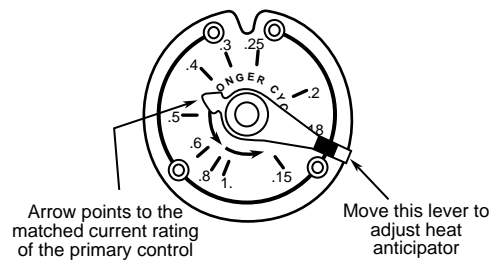

Figure 9. Anticipator adjustment

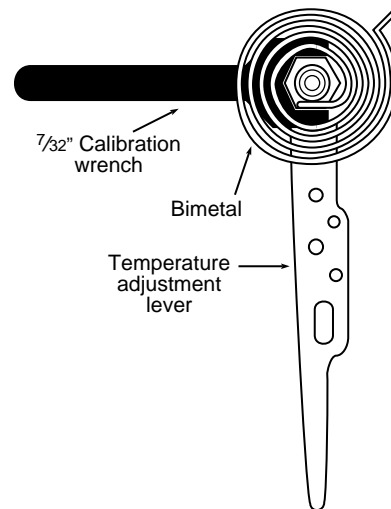

Figure 10. Calibrating thermostat

If you need further information about this product, write to us at:

WHITE-RODGERS DIVISION
Emerson Electric Co.
9797 Reavis Road
St. Louis, MO 63123-5398
Attn: Technical Service Department